

New agents for thromboprotection

A role for factor XII and XIIa inhibition

L. Labberton^{1,2}; E. Kenne^{1,2}; T. Renné^{1,2,3}

¹Clinical Chemistry, Department of Molecular Medicine and Surgery, Karolinska Institutet and University Hospital, Stockholm; ²Center of Molecular Medicine, Karolinska Institutet, Stockholm; ³Institute of Clinical Chemistry and Laboratory Medicine, University Medical Center Hamburg-Eppendorf, Germany

Keywords

Factor XII, contact system, anticoagulants, polyphosphate

Summary

Blood coagulation is essential for hemostasis, however excessive coagulation can lead to thrombosis. Factor XII starts the intrinsic coagulation pathway and contact-induced factor XII activation provides the mechanistic basis for the diagnostic aPTT clotting assay. Despite its function for fibrin formation in test tubes, patients and animals lacking factor XII have a completely normal hemostasis. The lack of a bleeding tendency observed in factor XII deficiency states is in sharp contrast to deficiencies of other components of the coagulation cascade and factor XII has been considered to have no function for coagulation in vivo. Recently, experimental animal models showed that factor XII is activated by an inorganic polymer, polyphosphate, which is released from procoagulant

platelets and that polyphosphate-driven factor XII activation has an essential role in pathologic thrombus formation. Cumulatively, the data suggest to target polyphosphate, factor XII, or its activated form factor XIIa for anticoagulation. As the factor XII pathway specifically contributes to thrombosis but not to hemostasis, interference with this pathway provides a unique opportunity for safe anticoagulation that is not associated with excess bleeding.

The review summarizes current knowledge on factor XII functions, activators and inhibitors.

Schlüsselwörter

Faktor XII, Kontaktphasensystem, Antikoagulation, Polyphosphat

Zusammenfassung

Die Blutgerinnung ist notwendig zur Blutstillung bei Verletzungen, kann aber auch zu

Thrombosen führen. Faktor XII startet die intrinsische Blutgerinnungskaskade und dieser Mechanismus ist die Basis für den millionenfach eingesetzten aPTT-Gerinnungstest. Trotz seiner Bedeutung für die Fibrinbildung im Reagenzglas ist ein Mangel an Faktor XII weder bei Mensch noch Tier mit einer erhöhten pathologischen Blutungsneigung assoziiert. Daher dachte man über Jahrzehnte, dass Faktor XII keine Funktion für die Blutgerinnung in vivo habe. In den vergangenen Jahren haben experimentelle Tiermodelle gezeigt, dass Faktor XII durch das anorganische Polymer Polyphosphat auf prokoagulant Thrombozyten aktiviert wird. Die Polyphosphat-getriebene Faktor-XII-vermittelte Fibrinbildung hat eine essenzielle Funktion für die Bildung von Thromben, aber keine Funktion für hämostatische Mechanismen. Daher sind Polyphosphat, Faktor-XII-Zymogen und die aktive Protease attraktive Zielstrukturen für sichere Antikoagulantien, die im Gegensatz zu aktuellen Medikamenten nicht mit Blutungsneigung assoziiert sind.

Diese Übersichtsarbeit fasst das aktuelle Wissen über Faktor XII, seinen Aktivator Polyphosphat und Inhibitoren dieser beiden Substanzen zusammen.

Correspondence to:

Thomas Renné, M.D. Ph.D.
Clinical Chemistry, Department of Molecular Medicine and Surgery, Karolinska Institutet
Karolinska University Hospital Solna (L2:05)
171 76 Stockholm, Sweden
Tel. +46/8/51 77 33 90, +49/(0)40/741 05 89 84
Fax +46/31 03 76, +49/(0)40/741 05 75 76
E-mail: thomas@renne.net

**Inhibition von Faktor XII und Faktor XIIa
Neue Strategien zur sicheren Antikoagulation
Hämostasologie 2015; 35: 338–350
<http://dx.doi.org/10.5482/HAMO-14-11-0060>**

received: November 9, 2014

accepted in revised form: January 13, 2015

epub ahead of print: January 22, 2015

FXII driven contact system

The contact system is a plasma protease cascade that consists of factor XII (FXII), factor XI (FXI), plasma kallikrein (PK), C1 esterase inhibitor (C1INH), and the non-enzymatic cofactor high molecular weight kininogen (HK). The contact system reac-

tion cascade is initiated by FXII contact mediated activation and drives proinflammatory and procoagulant reactions (1). Contact system proteins locally assemble on heparan and chondroitin sulphate type proteoglycans on various cardiovascular cells such as platelets, leukocytes and endothelial cells (2, 3). Other proteins such as

gC1q receptor (gC1qR), cytokeratin-1 (CK1) and urokinase plasminogen activator receptor (uPAR) contribute to HK binding to endothelial cells (4). FXII and HK directly bind to cardiovascular cell surfaces while PK and FXI form bimolecular complexes with HK and are indirectly anchored to cell surfaces via HK. FXII, Hage-

man factor, is produced and secreted to the plasma by hepatocytes. The glycoprotein, with an apparent molecular weight of 80 kDa, is the product of a single gene that maps to chromosome 5 in humans. FXII circulates in plasma as a single chain zymogen form with a half-life of about 2 days (5). Activated FXII (FXIIa) initiates fibrin formation by the intrinsic pathway of coagulation via activation of its substrate FXI, and bradykinin-production by the proinflammatory kallikrein-kinin system via PK (► Fig. 1) (6). Independent of its enzymatic activity, FXII zymogen binding to uPAR stimulates cell growth and proliferation of endothelial cells leading to angiogenesis (7). The FXII driven contact system is highly conserved in mammals (8). The system is absent in inframammalian species and FXII, FXI or HK genes are absent in vertebrates such as birds or fish (9),

suggesting that the contact system has evolved late during evolution.

Factor XII is composed of eight domains/regions, some of which share homology with other plasma proteins. Starting from the N-terminus FXII contains a fibronectin domain type II, an epidermal-growth-factor-like domain, a fibronectin domain type I, a second epidermal-growth-factor-like domain, a kringle domain, a proline-rich region and the catalytic domain (5). Surface binding induces a conformational shift in FXII zymogen that alters its conformation and leads to generation of a (partially) proteolytic active form. Surface bound FXII activates itself by limited proteolysis at a single peptide bond Arg₃₅₃-Val₃₅₄ (auto-activation). This initial cleavage leads to generation of the two-chain active protease composed of a heavy and a light chain of 353 and 243 amino

acids respectively, termed α -FXIIa. A disulfide bridge connects the α -FXIIa heavy and light chains. α -FXIIa cleaves its substrates FXI and plasma prekallikrein generating activated FXI (FXIa) and PK. PK in turn further activates FXII zymogen, thereby amplifying the initial signal (hetero-activation) (10).

Two additional proteolytic steps occur in α -FXIIa at positions Arg₃₃₄-Asn₃₃₅ and Arg₃₄₃-Leu₃₄₄. These proteolytic steps release the FXII light chain fragment that contains the protease domain from the heavy chain, which remains surface bound. The light chain fragment, β -FXIIa of 28 kDa (► Fig. 2) retains its proteolytic activity towards plasma prekallikrein but does not have the capacity to activate FXI in plasma (11). Thus β -FXIIa cannot activate the intrinsic pathway of coagulation. In addition to PK and FXI, FXIIa can activate

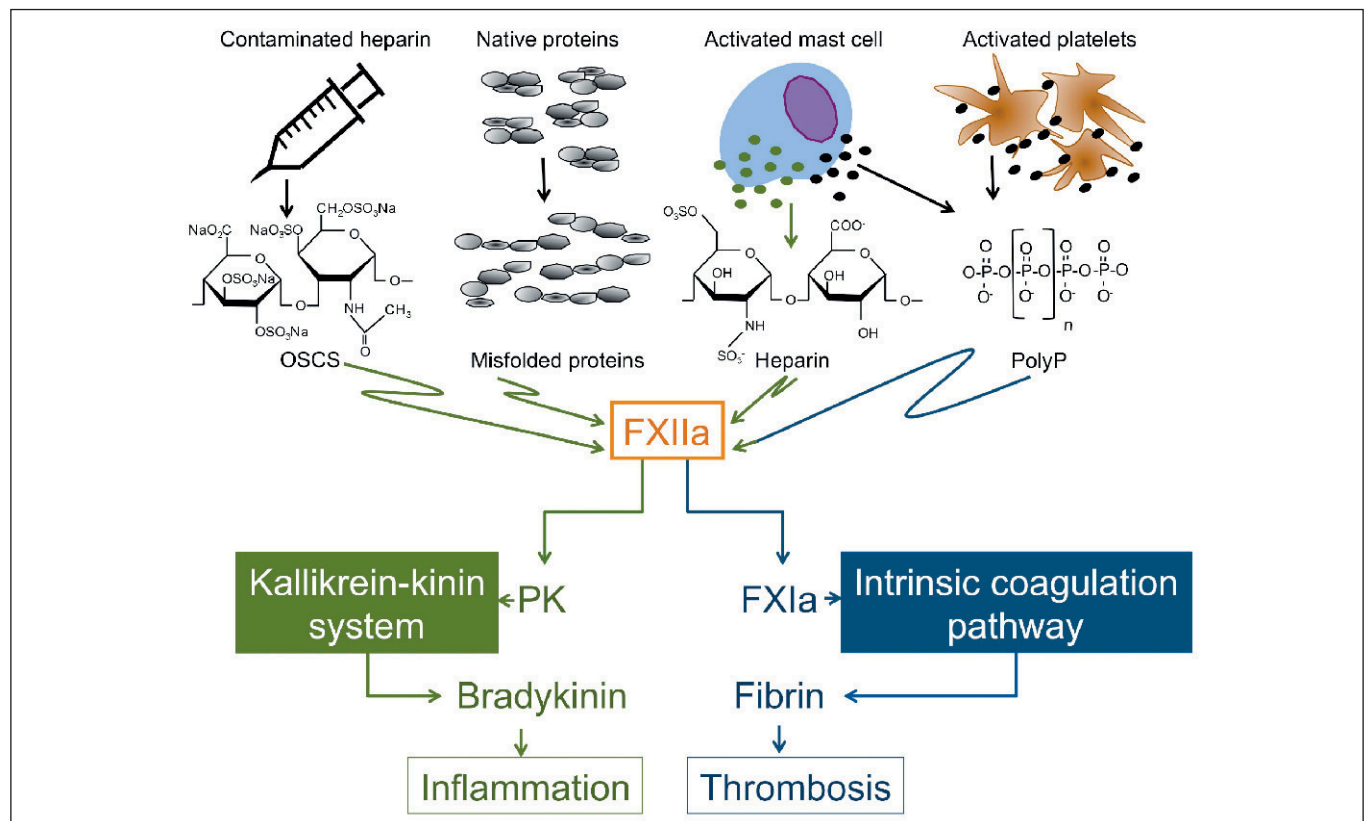

Fig. 1 The factor XII-driven contact system is a procoagulant and proinflammatory plasma protease cascade, which is initiated by activation of factor XII (FXII). Activated FXII (FXIIa) in turn activates factor XI (FXIa), which initiates fibrin formation by the intrinsic pathway of coagulation. Alternatively FXIIa triggers bradykinin-production by activating the proinflammatory kallikrein-kinin system via plasma kallikrein (PK). FXII zymogen is activated upon binding to contact activators. Established FXII contact activators

are misfolded proteins, heparin (released from activated mast cells), polyphosphates (polyP, released from activated platelets and mast cells) and the not naturally occurring over-sulfated chondroitin sulfate (OSCS), a heparin contaminant. OSCS, misfolded proteins and heparin selectively activate the kallikrein-kinin system pathway, while polyP trigger both the kallikrein-kinin system and the intrinsic coagulation pathway.

the classical pathway of complement, the fibrinolytic system and factor VII (FVII). Classical papers show that cold induced activation of FVII occurs by FXIIa dependent mechanisms, which might have some importance for diagnostic coagulation analysis when plasma has been stored at 4°C (12). FXIIa promotes fibrinolysis by activating plasminogen (13), however, binding of FXIIa to fibrin also leads to compact fibrin structures with increased fiber density and reduced pore size, resulting in decreased fibrinolysis (14). The *in vivo* relevance of these reactions, however, remains to be established. Enzymatic activity of FXIIa and PK is regulated by their endogenous plasma inhibitors C1 esterase inhibitor (C1INH) and antithrombin III (15).

FXII in inflammation

FXIIa initiates formation of the inflammatory mediator bradykinin (BK) via PK mediated proteolytic cleavage of the high molecular weight BK-precursor HK. FXII deficiency reduces plasma BK levels by

50%, indicating that alternative FXII-independent mechanisms of BK formation from HK exist (16). Other proteases such as neutrophil elastase and mast cell derived tryptase process HK to BK at sites of inflammation (17). Plasma prekallikrein complexed to HK on cell surfaces can be activated to PK by heat shock protein 90 or prolylcarboxypeptidase, respectively, in a FXII-independent manner (18, 19). BK is a peptide hormone and acts through stimulation of G-protein coupled kinin B2 receptors (B2R) that increase intracellular calcium ($[Ca^{2+}]_i$) in smooth muscle and endothelial cells. $[Ca^{2+}]_i$ in turn can activate multiple intracellular signaling cascades, including the phospholipase A2 pathway that releases arachidonic acid that in turn is converted to prostaglandins (e.g. PGI₂) in a cyclooxygenase-dependent manner. Increase in $[Ca^{2+}]_i$ is a potent stimulator of endothelial nitric-oxide synthase (eNOS) resulting in formation of nitric oxide that leads to vasodilation and platelet inhibition. Carboxypeptidases cleave BK to form des-Arg⁹-BK that is the principal ligand of kinin B1-receptors (B1R). B2R are

constitutively expressed in multiple tissues, while B1R are not found on cellular surfaces under normal (healthy) conditions. Expression of B1R is inducible in an IL1b-dependent manner during pathological events such as tissue injury or inflammation (20). Additional effects of BK-induced increase in $[Ca^{2+}]_i$ is stimulation of protein kinase C activity (21). Protein kinase C phosphorylates vasodilator-stimulated phosphoprotein (VASP), which is a key regulator of cortical cytoskeletal organization (22, 23). VASP phosphorylation leads to disassembly of actin stress fibers at interendothelial junctions (24). Taken together, BK signaling initiates a plethora of proinflammatory responses that dilate vessels, increase vascular permeability (25) and induce chemotaxis of neutrophils indirectly in a leukotriene B4 and B1R signaling dependent manner (26).

Excessive BK formation contributes to human disease states. BK-mediated edema formation is a result of deficiency in a functional C1INH. Hereditary angioedema (HAE) is a rare autosomal dominant disorder that is clinically associated with recurrent skin swelling, abdominal pain attacks and potentially life-threatening upper airway obstructions. HAE develops in individuals deficient in C1INH (HAE type I), or individuals with a dysfunctional C1INH protein (HAE type II) (27). Besides these two classical HAE types a third C1INH-independent variant, HAE type III, exists that almost exclusively affects women. HAE type III patients have normal C1INH concentration and activity in plasma, but still suffer from edema. A genome wide linkage study showed that HAE type III is associated with a single point mutation in FXII, (Thr309Lys or Thr309Arg), that results in increased FXII activity without altering FXII plasma levels. Enhanced FXII enzymatic plasma activity in HAE III leads to enhanced BK production via unidentified mechanisms that result in angioedema (28).

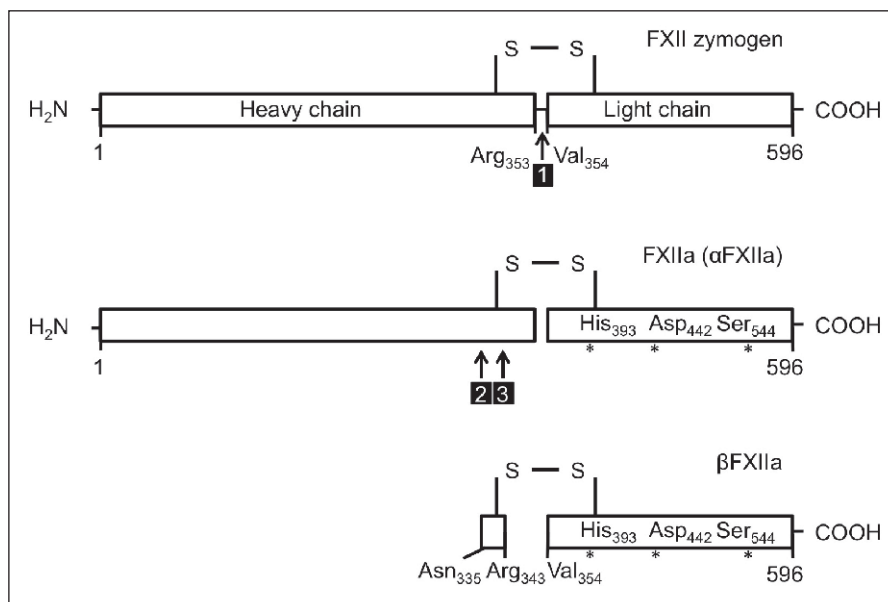

Fig. 2 Gross structure of FXII: Factor XII zymogen contains a heavy chain with the surface binding site and a light chain, which bears the enzymatic activity of a serine protease. Cleavage of the peptide bond between Arg₃₅₃ and Val₃₅₄ (dark 1) converts FXII zymogen to the active enzyme, FXIIa, where the heavy and light chains are connected via a disulfide bridge between Cys₃₄₀ and Cys₃₆₇. Asterisks indicate the FXIIa catalytic triad. Two additional proteolytic steps occur in FXIIa at peptide bonds Arg₃₃₄-Asn₃₃₅ (dark 2) and Arg₃₄₃-Leu₃₄₄ (dark 3) that releases the light chain fragment (βFXIIa) with the proteolytic activity from the surface bound FXII heavy chain.

FXII in coagulation

The protease thrombin is a major product of the plasma coagulation system. Thrombin converts fibrinogen into insoluble fi-

brin. In the classical cascade/waterfall model coagulation can be initiated by two distinct mechanisms triggered by either vessel wall (extrinsic) or blood borne (intrinsic) factors. The extrinsic pathway starts when tissue factor (TF) is exposed at vascular injury sites and binds to coagulation factor VII, which is activated to factor VIIa (FVIIa). The TF/FVIIa complex generates small amounts of activated factor X (FXa) that trigger thrombin generation, sufficient to activate platelets, to convert fibrinogen to fibrin and to activate factors V (FV) and VIII (FVIII) (29, 30). Furthermore, the TF/FVIIa complex functions as a potent activator of factor IX (FIX) and the vast majority of the FXa is produced by the FVIIIa/FIXa complex (intrinsic FXase) that is ~50 times more efficient in converting FX to FXa than the TF/FVIIa complex (extrinsic FXase; 29). The FXII driven intrinsic pathway of coagulation is initiated by FXIIa mediated factor XI (FXI) cleavage to form active FXI (FXIa), which in turn promotes coagulation via Ca^{2+} dependent activation of FIX resulting in the activation of FX. FXa in complex with the cofactor factor Va converts prothrombin into thrombin (31).

The activated partial thromboplastin time (aPTT) is a diagnostic coagulation assay that is commonly used to monitor heparin therapy, analyze for lupus anticoagulant and for preoperative screenings. The aPTT assay is based on FXII contact activation by non-physiological surfaces such as kaolin or ellagic acid. Despite its importance for fibrin formation *in vitro*, FXII has been considered to have no function for coagulation *in vivo*. The premise was based on the fact that patients lacking FXII have a completely normal hemostatic capacity and do not suffer from pathologic spontaneous or injury-related bleeding despite their largely prolonged aPTT (32). The lack of a bleeding tendency observed with FXII deficiency is in sharp contrast to deficiencies of other components of the coagulation cascade, such as von Willebrand factor (vWF), FVII, FVIII or FIX, that are associated with severe spontaneous and injury associated bleedings (33). The absence of increased bleeding in FXII deficiency states leads to the hypothesis that fibrin formation *in vivo* is largely,

if not exclusively, initiated through the extrinsic pathway of coagulation. We generated FXII deficient mice (34) and found that the animals were largely protected from vessel occlusive thrombosis in venous and arterial vascular beds in response to chemical and mechanical types of endothelial injury (35). Similarly to their human counterparts, mice lacking FXII have a completely normal hemostatic capacity and do not bleed excessively (34). FXII null mice are also protected from lethal contact-induced pulmonary embolism (35) and ischemic brain injury in the tMCAO model (36). Reconstitution of FXII deficient mice with human FXII protein restored both the prolonged aPTT in plasma and defective thrombus formation *in vivo* (35). The reconstitution experiments suggest that FXII operates similarly among mice and humans. Similar to FXII deficiency, individuals and genetically modified mice lacking the contact proteins PK or HK have a normal hemostasis (37). The absence of excessive bleeding in contact system deficient humans and mice indicate that FXII and the downstream proteins of the system are specifically important for thrombosis but not required for hemostasis (38). Taken together, the findings with contact system deficient mice challenge the dogma of a coagulation balance, as thrombosis is largely defective whereas the hemostatic system is normal. In contrast to normal hemostasis in FXII deficient individuals FXI-deficiency is associated with increased bleeding (Hemophilia C) that is usually mild and injury related (39). The rationale for bleeding in FXI but not in FXII deficiency states is provided by the revised model of coagulation that proposes thrombin production by the tissue factor pathway as a major FXI activator in plasma *ex vivo*. The revised model of coagulation provides a mechanism for FXI activation that operates independently of FXII. Analysis of the importance of this pathway *in vivo* awaits further studies (40).

Activation of FXII

Surface binding induces a conformational change in FXII that activates the zymogen

resulting in the active protease FXIIa (11). FXII zymogen binds to anionic and hydrophilic surfaces, however the precise surface binding sites in FXII and requirements of the surface for inducing contact activation have remained somehow unclear (41, 42).

FXII contact-activation on non-physiological surfaces

Non-physiological negatively charged surfaces such as kaolin, glass, or some polymers are known to have the capacity for inducing FXII contact activation (10). The commonly used diagnostic aPTT coagulation assay takes advantage of FXII's ability to auto-activate upon binding to the white clay material kaolin. Another clinically used contact-activator for triggering aPTT assays, ellagic acid, contains insoluble aggregates of ellagic acid-metal-ion complexes. Consistently, immobilized transition metals such as Ni^{2+} , Cu^{2+} , Co^{2+} or Zn^{2+} on the surface of synthetic phospholipid micelles stimulate FXII-driven coagulation (43). During various clinical procedures, blood comes into contact with medical devices. Initially abundant plasma proteins such as fibrinogen rapidly adsorb on the surface. Subsequently other plasma born proteins such as FXII adhere to the surface and may become activated (44). Indeed, various clinically used surfaces, such as polyvinylchloride tubing or membranes used for hemodialysis and extracorporeal circulation are known to be associated with a prothrombotic risk (45, 46). Supporting a role of FXII activation upon contact to these surfaces, increased plasma levels of FXIIa and BK are found in patients with cardiopulmonary bypass (47). In addition to contact activating polymers in medical devices the synthetic polysaccharide high molecular weight dextran sulphate (DXS) is used as a contact system activator in experimental settings (48). Intravenous injection of DXS in pigs leads to hypotension that is completely blocked by pretreatment with the B2R antagonist Icatibant (49). The contact activator DXS specifically initiates the kallikrein-kinin system but does not trigger fibrin formation via the intrinsic pathway of coagulation *in vivo* (50).

FXII contact-activation on natural FXII activators

The finding that inhibition of FXII activity interferes with thrombosis without a risk of bleeding has initiated screens for naturally occurring FXII contact activators to further understand the mechanism of FXII activation. The contact system proteins locally assemble on the surface of bacterial pathogens (51). FXII-contact activation by microbial agents initiates plasma host-defense systems including complement and coagulation systems. Septic disease states are associated with contact system activation (52). Non-collagenous and collagenous proteins in the subendothelial basal membrane contribute to FXII activation following vascular injury. Laminin is among the most abundant non-collagenous proteins in the extracellular matrix. It accelerates FXII activation in a purified system, and shortens the clotting time of recalcified plasma in a FXI- and FXII-dependent manner (53). Type I collagen has the capacity to initiate the intrinsic coagulation system in the absence of platelets, indicating that some types of collagen function as a FXII contact activator (54). Arteriosclerotic plaque material initiates thrombin generation in a FXII-dependent manner similarly to collagen. These data support the hypothesis that FXII plays a role in plaque-induced coagulation. Indeed, recent studies using intravital microscopy have shown that FXIIa accumulates in the luminal portions of the thrombi (55). Collagen is not soluble and found at the vascular wall, suggesting that FXIIa at the leading edge of a thrombus is not directly produced by collagen mediated contact activation. The source of FXII contact activators within the developing thrombus is matter of ongoing research. Possible FXII activators that contribute to thrombus formations are microparticles (MPs). MPs are small membrane surrounded vesicles that are shed from different cell types such as platelets, monocytes, endothelial cells and erythrocytes. MPs from platelets and erythrocytes initiate thrombin generation independently of TF in a FXII-dependent manner and these MPs completely fail to induce thrombin generation in FXII-deficient plasma. The physiological relevance,

mechanisms and in vivo contribution of the intrinsic pathway of coagulation induced by MPs require further investigation (56).

FXII activation has been associated with mast cell activation for decades. Heparin is a linear and highly sulphated polysaccharide that is exclusively found in mast cells, and activates the contact system in vitro (57). IgE/antigen activated mast cells release the polysaccharide that initiates FXII contact-activation resulting in BK formation via the kallikrein-kinin system. BK produced by aberrant activated mast cells contributes to swelling, anaphylactic, and inflammatory symptoms. Vice versa, deficiency in FXII or B2R largely protects mice from heparin and IgE/allergen-activated mast cell-induced edema formation (58). Sudden release of mast cell mediators into the circulation drives anaphylactic attacks. For decades it has been known that anaphylaxis is associated with a transient prolongation of the aPTT (while tissue factor-driven coagulation is normal). Heparin levels are largely elevated during anaphylactic reactions in patients and FXII is activated. The intensity of FXII activation correlates with BK formation and severity of clinical symptoms (grade of anaphylaxis) (59). In addition to FXII, PK and HK are activated in plasma samples from anaphylactic patients, which were taken during an anaphylactic attack, while in basal conditions no significant activation of the contact system is detectable. Cumulatively, the animal models and data in patients suggest a role of the contact system for anaphylaxis. Consistently, targeting BK formation or signaling in IgE/allergen-driven hypersensitivity reactions in mouse models results in attenuated mast cell-driven adverse effects (59). Thus pharmacological inhibition of BK formation or signaling could be promising strategies for interfering with anaphylaxis and possibly other allergic diseases. Similarly to DXS, heparin does not trigger procoagulant reactions and does not induce FXI activation (58). Clinically used heparin represents a heterogeneous agent and both chain lengths and modifications of the polysaccharide backbone varies among heparins from different manufacturers (60). In 2008 there was a dramatic increase in lethal acute hypersen-

sitivity reactions in patients receiving intravenous heparin from a single manufacturer (61). A contaminant was identified that was characterized as non-naturally occurring over-sulfated chondroitin sulfate (OSCS) (62). OSCS shares similarities with DXS in respect to charge density that determines the potency for FXII activation of the contact activator. OSCS has a higher negative charge (average of 4.0 sulfate residues per disaccharide) compared to mast cell heparin (average of 2.7 sulfate residues per disaccharide) and therefore triggers contact activation more potently (58). Other molecules that possess sulphur-containing groups e.g. sulfatides and amylose sulphates have some possibilities for activating FXII dependent on clustering of these charges. Sulfatides of brain, kidney and erythrocyte cell membranes have procoagulant activity and trigger PK-like amidolytic activities in plasma (63). Other activators, which lead to the activation of the kallikrein-kinin system without inducing coagulation, include misfolded protein-aggregates. FXIIa and PK are detectable in blood from patients with systemic amyloidosis, when insoluble amyloid proteins deposit in organs (64).

Nucleic acids are anionic polymers and can provide a surface that allows for binding and contact activation of FXII. Extracellular RNA was identified as a FXII activator and targeting the phosphoester bonds in the polymer backbone with RNase provides thromboprotection in mouse models (65). Similarly single-stranded DNA is an efficient activator of FXII in vitro (66). Neutrophil extracellular traps (NETs) consist of DNA and provide a surface for contact activation (51). The capacity of NETs to trigger thrombus propagation is significantly increased in the presence of activated platelets suggesting that platelet derived mediators contribute to propagation of thrombus formation in NETs-driven deep vein thrombosis (67).

Polyphosphate as a natural FXII activator

Multiple independent studies have shown that activated platelets promote plasma clotting and that procoagulant activity of

activated platelets is strictly dependent on blood coagulation FXII (68–70). Activated platelets also initiate FXII-driven BK formation in plasma (71). However, it was not known how FXII is activated by procoagulant platelets (72).

Polyphosphates (polyP) are polymers of orthophosphate residues that are linear linked by energy-rich phosphoranehydride bonds. Human platelets contain vast amounts of polyP in their dense granules (≈ 10 pmol/ 10^8 platelets) that are secreted upon platelet activation (73). Presumably, local polyP concentrations are high in platelet rich-thrombi (74). Similarly, mast cells contain polyP in their secretory vesicles. Both activation of platelets and mast cells leads to the release of these granules and liberation of polyP (73, 75). PolyP plasma levels as concluded from measurements of monophosphate are in the submicromolar range (76). PolyP is ubiquitously found in nature in all cells from bacteria to mammals. In the cardiovascular system endothelial cells, granulocytes and erythrocytes have been shown to contain polyP (76–78). Synthetic polyP is used as water softeners, fertilizers, and food additives due to its non-toxicity, inexpensiveness, and biodegradability (79). The function of polyP has been studied mainly in prokaryotes where it acts as a phosphate and energy storage pool, in the formation of membrane channels, cell envelope formation, gene activity control, stress response and stationary phase adaptation (80). In contrast to bacteria the polyP synthesis pathway in mammalian cells is unknown and the biological functions of polyP are not well defined.

PolyP shares a similar polyanion backbone with the FXII-activator RNA. PolyP released from platelet dense granules have a mean chain length of 70–100 phosphate units and initiate FXII contact activation in plasma (77). Synthetic polyP of this chain length also triggers plasma coagulation in a FXII-dependent manner (81). Using thrombosis and edema models in mice, and a human disease model we have identified platelet polyP as the *in vivo* activator of FXII and have shown that polyP-driven FXII activation has critical functions for platelet-driven thrombosis and inflammation (77). Addition of synthetic platelet size polyP restored defective plasma clot-

ting of patients with severe hemophilia A or B, or patients receiving the anticoagulant warfarin (82), and also reversed the defect in VWF-dependent platelet agglutination in patients with type I von Willebrand disease (83). Patients with Hermansky-Pudlak syndrome have a dysfunctional biogenesis of platelet dense granules, which leads to prolonged bleeding times in addition to other clinical features such as albinism (84). These patients have substantially lowered levels of polyP in platelets compared to healthy controls (85) and delayed *in vitro* clotting times in platelet rich plasma. Defective fibrin formation in Hermansky-Pudlak patient samples was shortened on addition of platelet polyP (77). FXII deficient mice and animals with combined deficiency in factors XII and XI (FXI^{-/-}/FXII^{-/-}) are similarly protected from polyP induced lethal pulmonary embolism as FXII deficient mice, suggesting that the polymer drives fibrin formation via the classical intrinsic pathway (77). Taken together polyP secreted by activated platelets and mast cells is an endogenous FXII activator that drives coagulation and inflammatory pathways.

Besides inducing FXII contact activation, platelet size polyP accelerate the activation of FXI by thrombin (87), and the conversion of factor V to Va by thrombin, FXa and FXIa (81, 88). The rapid formation of FVa by platelet-derived polyP causes a localized thrombin burst at the clot site and antagonizes the anticoagulant activity of tissue factor pathway inhibitor (89). Furthermore, polyP integration into fibrin clots results in thicker fibrin fibers and altered fibrin structures. Fibrin clots containing polyP dissolve slower as polyP block the binding of tissue plasminogen activator and plasminogen to fibrin. As a consequence of increased thrombin generation polyP also slow down fibrinolysis by enhancing the activity of thrombin-activatable fibrinolysis inhibitor (81, 90). PolyP exerts different effects on blood clotting depending on polymer length and ability to activate FXII increases with polyP chain length (89).

Despite of all above-mentioned data the concept of platelet-induced activation of FXII was challenged in a study, claiming that platelets and polyP do not activate

FXII. However, these results are possibly due to wrong handling and extended storage of polyP resulting in the use of insoluble and degraded polyP (91, 92). Indeed, recently independent groups have confirmed a critical role of platelet polyP for FXII-driven thrombosis using genetic and pharmacologic approaches. IP6K1 deficient mice have been generated that similarly to Hermansky-Pudlak syndrome patients have significantly reduced platelet polyP levels that are associated with a prolonged FXII-driven clotting time. Supporting the critical role of platelet polyP for thrombosis. IP6K1^{-/-} mice are similarly protected from lethal pulmonary thromboembolism (86) as FXII^{-/-} mice (35, 77). Furthermore specific polyP interfering agents have been generated. Targeting polyP inhibits platelet driven thrombus formation in arterial and venous thrombosis models *in vivo* (93). Taken together the new findings support a critical role of platelet polyP for thrombus formation.

Targeting FXII and FXIIa

Multiple animal models have shown an essential role of polyP-FXII for thrombosis. On the other hand, the fact that FXII deficient patients have no abnormal bleeding diathesis raises the interesting prospect that drugs targeting FXII or the active form FXIIa will produce antithrombotic effects without compromising hemostasis. Blocking zymogen FXII with an antibody (15H8) completely inhibited the prothrombotic effect of FXII in a ferric chloride-induced mouse thrombosis model and a graft-induced baboon thrombosis model. 15H8 reduced fibrin and platelet accumulation downstream of an inserted graft, supporting the role for FXII in thrombus formation in primates (94). Antisense oligonucleotides (ASO) used to selective knockdown FXII in mice reduced thrombus formation in both arterial and venous thrombosis models, without an apparent effect on hemostasis (95). Additionally, ASO treatment in rabbits where catheters were implanted in the jugular vein attenuated catheter thrombosis (96). The major drawback of ASO treatment is that these drugs need to be repeatedly injected for

many weeks (up to 7 in baboons) in high amounts to sufficiently suppress FXII levels. Thus ASO-mediated knockdown FXII expression is not suitable for acute anti-thrombotic treatment.

There is a huge excess of FXII zymogen in plasma that by far exceeds the active protease FXIIa. To overcome this antigen

sink, FXIIa is considered to be a better drug target than FXII. Initial attempts to target FXIIa utilized corn trypsin inhibitor (CTI), a 12 kDa Kunitz-type inhibitor, which reversibly interacts with the active site of FXIIa. In catheter thrombosis models in rabbits, the time to catheter occlusion was significantly prolonged with CTI-coated

catheters compared to unmodified catheters (97). Another biological FXIIa inhibitor is Infestin 4, a serine protease inhibitor derived from the midgut of the kissing bug (*Triatoma infestans*), which uses infestins to prevent coagulation of ingested blood (98). Infestin 4 was fused to human albumin, to enhance its bioavailability and

Tab. 1 Targeting FXII, FXIIa and polyP

target	class	name	action	model	reference
FXII	antibodies	P 5–2–1	prevents FXII proteolytic cleavage	in plasma	(109)
		anti HF	inhibits FXII activation	in plasma	(110)
		B7C9	binds to FXII heavy chain	in plasma	(111)
		C6B7	inhibits FXII activation	sepsis in baboons	(112, 113)
		15H8	blocks FXII activation	thrombosis in mice and primates	(94)
	biological inhibitors	Hamaradin	inhibits FXII hetero-activation	in plasma	(114)
		Dimiconin	inhibits FXII activation	in plasma	(115)
	small molecule	bicyclic peptide	selective FXII inhibitor	in plasma	(116)
	oligonucleotides	ASO	selective FXII knockdown	thrombosis catheter-induced	(95)
				thrombosis in rabbits	(96)
RNA-aptamer		high affinity FXII inhibitor	in plasma	(117)	
FXIIa	antibodies	2/215	binds to α -FXIIa/ β -FXIIa	in plasma	(118)
		3F7	binds FXIIa enzymatic pocket	thrombosis and ECMO in rabbits	(102)
	biological inhibitors	CTI	inactive complex with FXIIa	in plasma catheter-induced	(119)
				thrombosis in rabbits	(97)
		Ecotin	binding to FXIIa	in plasma	(120)
		C1-esterase inhibitor	binding to FXIIa	ischemia reperfusion and sepsis in animals	(121)
		YAP	binding to FXIIa	in plasma	(122)
		Infestin 4	inhibits FXIIa	in plasma	(98)
	thrombosis models			(99)	
	3-carboxide-coumarin	binding to FXIIa	ischemic brain model	(100)	
in plasma			(123)		
small molecule	Ir-CPI	binding to FXIIa	arterial thrombosis	(124)	
			in plasma	(123)	
polyP	biological inhibitors	polyphosphatase	degradation polyP	in plasma pulmonary	(87)
				embolism model	(77)
		PdSP15a/b	binding polyP	in plasma vascular leakage	(104)
		spermine	binding polyP	in plasma	(106)
		polymixin B	binding polyP	in plasma thrombosis vascular leakage	(106)
	small molecule	Surfen	binding polyP	in plasma	(106)
				in plasma	(106)
	polycationic polymers	polyethylenimine	binding polyP	in plasma thrombosis	(106)
				in plasma thrombosis vascular leakage	(105, 106)
				in plasma thrombosis	(93)

treatment protects mice in experimental thrombosis models (99) as well as decreases the morbidity of silent brain ischemia in mice (100). However, Infestin-4 at high concentrations in vivo exerts off-target effects on FXa, which presents a limitation of this molecule (101).

Recently, a fully humanized recombinant antibody (3F7) was developed that specifically binds into the enzymatic pocket on FXIIa and interfered with FXIIa activity and FXIIa-mediated coagulation in human plasma. 3F7 abolished thrombus formation of human and mouse blood under arterial and venous flow in laminar flow chambers coated with collagens. The anti-FXIIa antibody also blocked FeCl₃ triggered arterial thrombosis in mouse models. Moreover, 3F7 provided thromboprotection in an extracorporeal membrane oxygenation (ECMO) cardiopulmonary bypass system in rabbits. Thromboprotection in this clinically relevant ECMO model conferred by 3F7 was as efficient as heparin, however, unlike heparin, 3F7 treatment did not impair the hemostatic capacity and did not cause increased bleeding (102). The data obtained with 3F7 indicate that targeting FXIIa provides a new safe mode of anticoagulation that is not complicated by excess bleeding and therefore it is motivating to test the antibody in other thrombosis-prone scenarios. For a complete overview of currently available FXII and FXIIa inhibitors (► Tab. 1).

Targeting polyphosphate

As targeting FXII and FXIIa interferes with thrombosis, blocking the endogenous FXII contact activator polyP is a tempting novel antithrombotic strategy. Phosphatases are enzymes that hydrolyze phosphate bonds and degrade polyP (91). Targeting polyP with phosphatases interfered with procoagulant activity of activated platelets and protected mice in a polyP-driven lethal pulmonary embolism model (77). Bacterial exopolyphosphatase also abrogated polyP-amplified FXI feedback activation by thrombin (87). PdSP15a/b belongs to the insect odorant-binding proteins that are the most abundant group of proteins in the saliva of the sand fly (*Phlebotomus du-*

boscqi) (103). PdSP15a/b bind to polyP and inhibit polyP-driven FXII activation, the cleavage of FXI by FXIIa or thrombin, and polyP-induced plasma leakage in mouse models (104).

Polyamidoamine dendrimers (PAMAM) are polycationic polymers that bind with high affinity to RNA and polyP. PAMAM inhibit RNA and polyP-driven clotting in human plasma and whole blood in vitro. PAMAM have antithrombotic activities in carotid artery thrombosis and pulmonary embolism thrombosis models while only mildly compromising hemostasis (105, 106). Polymyxin B, a clinical antibiotic, is a polyP inhibitor, but also significantly reduces the procoagulant activity of RNA and non-physiologic, mineral-based activators of the contact pathway (106). However, PAMAM and polymyxin B show significant toxicity in vivo. PAMAM dendrimers contain multiple primary amines that are toxic (107, 108). Due to the toxicity of these agents, universal heparin reversal agents (UHRAs) are in the focus of current research. UHRAs contain multifunctional cationic groups, however these are shielded from non-specific interactions. In vivo toxicity studies showed that UHRAs are well tolerated in mice. UHRA compounds have high affinity for polyP in vitro and interfere with thrombosis caused by laser-induced injury in cremaster arterioles and chemical-induced injury in carotid arteries. Antithrombotic doses of UHRA cause less bleeding compared to unfractionated heparin in a mouse tail bleeding model suggesting that specific platelet polyP interfering agents are promising antithrombotic agents (93).

Future perspectives

Targeting FXII, FXIIa or polyP provides a unique and safe mode of interference with contact system reactions. Inhibitors of FXII/FXIIa and polyP have potent anticoagulant and anti-inflammatory activities that are not complicated by adverse side effects such as excess bleeding. Potent thromboprotection conferred by the FXIIa-neutralizing 3F7 antibody in a clinically relevant model warrants examination of this tool in other clinical settings.

Acknowledgements

This work was supported in part by grants from Vetenskapsrådet (K2013-65X-21462-014-5), Hjärt Lungfonden (20140741), Stockholms läns landsting (ALF, 20140464), the German Research Society (SFB841, SFB877), and a European Research Council grant (ERC-StG-2012-311575_F-12) to TR.

Conflict of interest

The authors declare that there are no conflicts of interest.

References

1. Renne T. The procoagulant and proinflammatory plasma contact system. *Semin Immunopathol* 2012; 34: 31–41.
2. Renne T, Muller-Esterl W. Cell surface-associated chondroitin sulfate proteoglycans bind contact phase factor H-kininogen. *FEBS Lett* 2001; 500: 36–40.
3. Renne T, Dedio J, David G, Muller-Esterl W. High molecular weight kininogen utilizes heparan sulfate proteoglycans for accumulation on endothelial cells. *J Biol Chem* 2000; 275: 33688–33696.
4. Shariat-Madar Z, Mahdi F, Schmaier AH. Assembly and activation of the plasma kallikrein/kinin system: a new interpretation. *Int Immunopharmacol* 2002; 2: 1841–1849.
5. Stavrou E, Schmaier AH. Factor XII: what does it contribute to our understanding of the physiology and pathophysiology of hemostasis & thrombosis. *Thromb Res* 2010; 125: 210–215.
6. Maas C, Oschatz C, Renne T. The plasma contact system 2.0. *Semin Thromb Hemost* 2011; 37: 375–381.
7. LaRusch GA, Mahdi F, Shariat-Madar Z et al. Factor XII stimulates ERK1/2 and Akt through uPAR, integrins, and the EGFR to initiate angiogenesis. *Blood* 2010; 115: 5111–5120.
8. Doolittle RF. Coagulation in vertebrates with a focus on evolution and inflammation. *J Innate Immun* 2011; 3: 9–16.
9. Ponczek MB, Gailani D, Doolittle RF. Evolution of the contact phase of vertebrate blood coagulation. *J Thromb Haemost* 2008; 6: 1876–1883.
10. Maas C, Renne T. Regulatory mechanisms of the plasma contact system. *Thromb Res* 2012; 129 (Suppl 2): S73–S76.
11. Kenne E, Renne T. Factor XII: a drug target for safe interference with thrombosis and inflammation. *Drug Discovery Today* 2014; 19: 1459–1464.
12. Palmer RN, Gralnick HR. Cold-induced contact surface activation of the prothrombin time in whole blood. *Blood* 1982; 59: 38–42.

13. Klufft C, Doonijewaard G, Emeis JJ. Role of the contact system in fibrinolysis. *Semin Thromb Hemost* 1987; 13: 50–68.
14. Konings J, Govers-Riemslog JW, Philippou H et al. Factor XIIa regulates the structure of the fibrin clot independently of thrombin generation through direct interaction with fibrin. *Blood* 2011; 118: 3942–3951.
15. Bjorkqvist J, Nickel KF, Stavrou E, Renne T. In vivo activation and functions of the protease factor XII. *Thromb Haemost* 2014; 112: 868–875.
16. Iwaki T, Castellino FJ. Plasma levels of bradykinin are suppressed in factor XII-deficient mice. *Thromb Haemost* 2006; 95: 1003–1010.
17. Coffman LG, Brown JC, Johnson DA et al. Cleavage of high-molecular-weight kininogen by elastase and trypsin is inhibited by ferritin. *Am J Physiol Lung Cell Mol Physiol* 2008; 294: L505–L515.
18. Joseph K, Tholanikunnel BG, Kaplan AP. Heat shock protein 90 catalyzes activation of the prekallikrein-kininogen complex in the absence of factor XII. *Proc Natl Acad Sci USA* 2002; 99: 896–900.
19. Shariat-Madar Z, Rahimy E, Mahdi F, Schmaier AH. Overexpression of prolylcarboxypeptidase enhances plasma prekallikrein activation on Chinese hamster ovary cells. *Am J Physiol Heart Circ Physiol* 2005; 289: H2697–H2703.
20. Bjorkqvist J, Jamsa A, Renne T. Plasma kallikrein: the bradykinin-producing enzyme. *Thromb Haemost* 2013; 110: 399–407.
21. Lindsay SL, Ramsey S, Aitchison M et al. Modulation of lamellipodial structure and dynamics by NO-dependent phosphorylation of VASP Ser239. *J Cell Sci* 2007; 120: 3011–3021.
22. Benz PM, Blume C, Moebius J et al. Cytoskeleton assembly at endothelial cell-cell contacts is regulated by alpha II-spectrin-VASP complexes. *J Cell Biol* 2008; 180: 205–219.
23. Anton KA, Sinclair J, Ohoka A et al. PKA-regulated VASP phosphorylation promotes extrusion of transformed cells from the epithelium. *J Cell Sci* 2014; 127: 3425–3433.
24. Tirupathi C, Ahmmed GU, Vogel SM, Malik AB. Ca²⁺ signaling, TRP channels, and endothelial permeability. *Microcirculation* 2006; 13: 693–708.
25. Renne T, Schuh K, Muller-Esterl W. Local bradykinin formation is controlled by glycosaminoglycans. *J Immunol* 2005; 175: 3377–3385.
26. Paegelow I, Trzeciak S, Bockmann S, Vietinghoff G. Migratory responses of polymorphonuclear leukocytes to kinin peptides. *Pharmacology* 2002; 66: 153–161.
27. Bjorkqvist J, Sala-Cunill A, Renne T. Hereditary angioedema: a bradykinin-mediated swelling disorder. *Thromb Haemost* 2013; 109: 368–374.
28. Cichon S, Martin L, Hennies HC et al. Increased activity of coagulation factor XII (Hageman factor) causes hereditary angioedema type III. *Am J Hum Genet* 2006; 79: 1098–1104.
29. Orfeo T, Brummel-Ziedins KE, Gissel M et al. The nature of the stable blood clot procoagulant activities. *J Biol Chem* 2008; 283: 9776–9786.
30. Bos MH, Camire RM. Blood coagulation factors V and VIII: Molecular Mechanisms of Procofactor Activation. *J Coagul Disord* 2010; 2: 19–27.
31. Gailani D, Renne T. Intrinsic pathway of coagulation and arterial thrombosis. *Arterioscler Thromb Vasc Biol* 2007; 27: 2507–2513.
32. Ratnoff OD, Colopy JE. A familial hemorrhagic trait associated with a deficiency of a clot-promoting fraction of plasma. *J Clin Invest* 1955; 34: 602–613.
33. Kumar R, Carcao M. Inherited abnormalities of coagulation: hemophilia, von Willebrand disease, and beyond. *Pediatr Clin North Am* 2013; 60: 1419–1441.
34. Pauer HU, Renne T, Hemmerlein B et al. Targeted deletion of murine coagulation factor XII gene—a model for contact phase activation in vivo. *Thromb Haemost* 2004; 92: 503–508.
35. Renne T, Pozgajova M, Gruner S et al. Defective thrombus formation in mice lacking coagulation factor XII. *J Exp Med* 2005; 202: 271–281.
36. Kleinschnitz C, Stoll G, Bendszus M et al. Targeting coagulation factor XII provides protection from pathological thrombosis in cerebral ischemia without interfering with hemostasis. *J Exp Med* 2006; 203: 513–518.
37. Girolami A, Allemand E, Bertozzi I et al. Thrombotic events in patients with congenital prekallikrein deficiency: a critical evaluation of all reported cases. *Acta Haematol* 2010; 123: 210–214.
38. Muller F, Gailani D, Renne T. Factor XI and XII as antithrombotic targets. *Curr Opin Hematol* 2011; 18: 349–355.
39. Renne T, Oschatz C, Seifert S, Muller F, Antovic J, Karlman M, et al. Factor XI deficiency in animal models. *J Thromb Haemost* 2009; 7 (Suppl 1): 79–83.
40. Kravtsov DV, Matafonov A, Tucker EI et al. Factor XI contributes to thrombin generation in the absence of factor XII. *Blood* 2009; 114: 452–458.
41. Mitropoulos KA. High affinity binding of factor XIIa to an electronegative surface controls the rates of factor XII and prekallikrein activation in vitro. *Thromb Res* 1999; 94: 117–129.
42. Vogler EA, Graper JC, Harper GR et al. Contact activation of the plasma coagulation cascade. I. Procoagulant surface chemistry and energy. *J Biomed Mater Res* 1995; 29: 1005–1016.
43. Mutch NJ, Waters EK, Morrissey JH. Immobilized transition metal ions stimulate contact activation and drive factor XII-mediated coagulation. *J Thromb Haemost* 2012; 10: 2108–2115.
44. Jordan SW, Chaikof EL. Novel thromboresistant materials. *J Vasc Surg* 2007; 45 (Suppl A): A104–A115.
45. Frank RD, Mueller U, Lanzmich R, Floege J. Factor XII activation markers do not reflect FXII dependence of thrombin generation induced by polyvinylchloride. *J Mater Sci Mater Med* 2013; 24: 2561–2567.
46. Svensson M, Friberger P, Lundstrom O, Stegmayer B. Activation of FXII during haemodialysis. *Scand J Clin Lab Invest* 1996; 56: 649–652.
47. Cugno M, Nussberger J, Biglioli P et al. Increase of bradykinin in plasma of patients undergoing cardiopulmonary bypass: the importance of lung exclusion. *Chest* 2001; 120: 1776–1782.
48. Bjorkqvist J, Lecher B, Maas C, Renne T. Zinc-dependent contact system activation induces vascular leakage and hypotension in rodents. *Biol Chem* 2013; 394: 1195–1204.
49. Siebeck M, Cheronis JC, Fink E et al. Dextran sulfate activates contact system and mediates arterial hypotension via B2 kinin receptors. *J Appl Physiol* 1994; 77: 2675–2680.
50. Renne T, Schmaier AH, Nickel KF et al. In vivo roles of factor XII. *Blood* 2012; 120: 4296–4303.
51. Oehmcke S, Morgelin M, Herwald H. Activation of the human contact system on neutrophil extracellular traps. *J Innate Immun* 2009; 1: 225–230.
52. Nickel KF, Renne T. Crosstalk of the plasma contact system with bacteria. *Thromb Res* 2012; 130 (Suppl 1): S78–S83.
53. White-Adams TC, Berny MA, Patel IA et al. Laminin promotes coagulation and thrombus formation in a factor XII-dependent manner. *J Thromb Haemost* 2010; 8: 1295–1301.
54. Van der Meijden PEJ, Munnix ICA, Auger JM et al. Dual role of collagen in factor XII-dependent thrombus formation. *Blood* 2009; 114: 881–890.
55. Kuijpers MJE, van der Meijden PEJ, Feijge MAH et al. Factor XII regulates the pathological process of thrombus formation on ruptured plaques. *Arterioscler Thromb Vasc Biol* 2014; 34: 1674–1680.
56. Van Der Meijden PE, Van Schilfgaarde M, Van Oerle R et al. Platelet- and erythrocyte-derived microparticles trigger thrombin generation via factor XIIa. *J Thromb Haemost* 2012; 10: 1355–1362.
57. Brunnee T, Reddigari SR, Shibayama Y et al. Mast cell derived heparin activates the contact system: a link to kinin generation in allergic reactions. *Clin Exp Allergy* 1997; 27: 653–663.
58. Oschatz C, Maas C, Lecher B et al. Mast cells increase vascular permeability by heparin-initiated bradykinin formation in vivo. *Immunity* 2011; 34: 258–268.
59. Sala-Cunill A, Bjorkqvist J, Senter R et al. Plasma contact system activation drives anaphylaxis in severe mast cell-mediated allergic reactions. *J Allergy Clin Immunol* 2014; doi: 10.1016/j.jaci.2014.07.057.
60. Bianchini P, Liverani L, Mascellani G, Parma B. Heterogeneity of unfractionated heparins studied in connection with species, source, and production processes. *Semin Thromb Hemost* 1997; 23: 3–10.
61. Blossom DB, Kallen AJ, Patel PR et al. Outbreak of adverse reactions associated with contaminated heparin. *N Engl J Med* 2008; 359: 2674–2684.
62. Guerrini M, Beccati D, Shriver Z et al. Oversulfated chondroitin sulfate is a contaminant in heparin associated with adverse clinical events. *Nat Biotechnol* 2008; 26: 669–675.
63. Rojkaer R, Schouboe I. The surface-dependent autoactivation mechanism of factor XII. *Eur J Biochem* 1997; 243: 160–166.
64. Maas C, Govers-Riemslog JW, Bouma B et al. Misfolded proteins activate factor XII in humans, leading to kallikrein formation without initiating coagulation. *J Clin Invest* 2008; 118: 3208–3218.
65. Kannemeier C, Shibamiya A, Nakazawa F et al. Extracellular RNA constitutes a natural procoagulant cofactor in blood coagulation. *Proc Natl Acad Sci USA* 2007; 104: 6388–6393.
66. Pavlov V, Zorn M, Kramer R. Probing single-stranded DNA and its biomolecular interactions through direct catalytic activation of factor XII, a protease of the blood coagulation cascade. *Biochem Biophys Res Commun* 2006; 349: 1011–1015.
67. Von Bruhl ML, Stark K, Steinhart A et al. Monocytes, neutrophils, and platelets cooperate to initiate and propagate venous thrombosis in mice in vivo. *J Exp Med* 2012; 209: 819–835.

68. Griffin JH. Role of surface in surface-dependent activation of Hageman factor (blood coagulation factor XII). *Proc Natl Acad Sci USA* 1978; 75: 1998–2002.
69. Johné J, Blume C, Benz PM et al. Platelets promote coagulation factor XII-mediated proteolytic cascade systems in plasma. *Biol Chem* 2006; 387: 173–178.
70. Back J, Sanchez J, Elgue G et al. Activated human platelets induce factor XIIa-mediated contact activation. *Biochem Biophys Res Commun* 2010; 391: 11–17.
71. Johné J, Blume C, Benz PM et al. Platelets promote coagulation factor XII-mediated proteolytic cascade systems in plasma. *Biol Chem* 2006; 387: 173–178.
72. Muller F, Renne T. Platelet polyphosphates: the nexus of primary and secondary hemostasis. *Scand J Clin Lab Invest* 2011; 71: 82–86.
73. Ruiz FA, Lea CR, Oldfield E, Docampo R. Human platelet dense granules contain polyphosphate and are similar to acidocalcisomes of bacteria and unicellular eukaryotes. *J Biol Chem* 2004; 279: 44250–44257.
74. Morrissey JH. Polyphosphate: a link between platelets, coagulation and inflammation. *Int J Hematol* 2012; 95: 346–352.
75. Moreno-Sanchez D, Hernandez-Ruiz L, Ruiz FA, Docampo R. Polyphosphate is a novel pro-inflammatory regulator of mast cells and is located in acidocalcisomes. *J Biol Chem* 2012; 287: 28435–28444.
76. Lorenz B, Leuck J, Kohl D et al. Anti-HIV-1 activity of inorganic polyphosphates. *J Acqui Immune Defic Syndr Hum Retroviro* 1997; 14: 110–118.
77. Muller F, Mutch NJ, Schenk WA et al. Platelet polyphosphates are proinflammatory and procoagulant mediators in vivo. *Cell* 2009; 139: 1143–1156.
78. Cowling RT, Birnboim HC. Incorporation of [P-32] orthophosphate into inorganic polyphosphates by human granulocytes and other human cell-types. *J Biol Chem* 1994; 269: 9480–9485.
79. Kulakovskaya TV, Vagabov VM, Kulaev IS. Inorganic polyphosphate in industry, agriculture and medicine: Modern state and outlook. *Process Biochem* 2012; 47: 1–10.
80. Kornberg A, Rao NN, Ault-Riche D. Inorganic polyphosphate: A molecule of many functions. *Ann Rev Biochem* 1999; 68: 89–125.
81. Smith SA, Mutch NJ, Baskar D et al. Polyphosphate modulates blood coagulation and fibrinolysis. *Proc Natl Acad Sci USA* 2006; 103: 903–908.
82. Smith SA, Morrissey JH. Polyphosphate as a general procoagulant agent. *J Thromb Haemost* 2008; 6: 1750–1756.
83. Montilla M, Hernandez-Ruiz L, Garcia-Cozar FJ et al. Polyphosphate binds to human von Willebrand factor in vivo and modulates its interaction with glycoprotein Ib. *J Thromb Haemost* 2012; 10: 2315–2323.
84. Gahl WA, Brantly M, Kaiser-Kupfer MI et al. Genetic defects and clinical characteristics of patients with a form of oculocutaneous albinism (Hermansky-Pudlak syndrome). *N Engl J Med* 1998; 338: 1258–1264.
85. Hernandez-Ruiz L, Saez-Benito A, Pujol-Moix N et al. Platelet inorganic polyphosphate decreases in patients with delta storage pool disease. *J Thromb Haemost* 2009; 7: 361–363.
86. Ghosh S, Shukla D, Suman K, Lakshmi BJ et al. Inositol hexakisphosphate kinase 1 maintains hemostasis in mice by regulating platelet polyphosphate levels. *Blood* 2013; 122: 1478–1486.
87. Choi SH, Smith SA, Morrissey JH. Polyphosphate is a cofactor for the activation of factor XI by thrombin. *Blood* 2011; 118: 6963–6970.
88. Choi SH, Smith SA, Morrissey JH. Polyphosphate accelerates factor V activation by factor XIa. *Thromb Haemost* 2014; 113: <http://dx.doi.org/10.1160/TH14-06-0515>
89. Smith SA, Choi SH, Davis-Harrison R et al. Polyphosphate exerts differential effects on blood clotting, depending on polymer size. *Blood* 2010; 116: 4353–4359.
90. Mutch NJ, Engel R, Uitte de Willige S et al. Polyphosphate modifies the fibrin network and downregulates fibrinolysis by attenuating binding of tPA and plasminogen to fibrin. *Blood* 2010; 115: 3980–3988.
91. Nickel KF, Spronk HM, Mutch NJ, Renne T. Time-dependent degradation and tissue factor addition mask the ability of platelet polyphosphates in activating factor XII-mediated coagulation. *Blood* 2013; 122: 3847–3849.
92. Morrissey JH, Smith SA. Comment on Faxalv et al. „Putting polyphosphates to the test: evidence against platelet-induced activation of factor XII“. *Blood* 2013; 122: <http://dx.doi.org/10.1182/blood-2013-05-499384>.
93. Travers RJ, Sheno RA, Kalathottukaren MT et al. Nontoxic polyphosphate inhibitors reduce thrombosis while sparing hemostasis. *Blood* 2014; 124: 3183–3190.
94. Matafonov A, Leung PY, Gailani AE et al. Factor XII inhibition reduces thrombus formation in a primate thrombosis model. *Blood* 2014; 123: 1739–1746.
95. Revenko AS, Gao DC, Crosby JR et al. Selective depletion of plasma prekallikrein or coagulation factor XII inhibits thrombosis in mice without increased risk of bleeding. *Blood* 2011; 118: 5302–5311.
96. Yau JW, Liao P, Fredenburgh JC et al. Selective depletion of factor XI or factor XII with antisense oligonucleotides attenuates catheter thrombosis in rabbits. *Blood* 2014; 123: 2102–2107.
97. Yau JW, Stafford AR, Liao P et al. Corn trypsin inhibitor coating attenuates the prothrombotic properties of catheters in vitro and in vivo. *Acta Biomaterial* 2012; 8: 4092–4100.
98. Campos IT, Tanaka-Azevedo AM, Tanaka AS. Identification and characterization of a novel factor XIIa inhibitor in the hematophagous insect, *Triatoma infestans* (Hemiptera: Reduviidae). *FEBS Lett* 2004; 577: 512–516.
99. Hagedorn I, Schmidbauer S, Pleines I et al. Factor XIIa inhibitor recombinant human albumin infestin-4 abolishes occlusive arterial thrombus formation without affecting bleeding. *Circulation* 2010; 121: 1510–1517.
100. Chen JW, Figueiredo JL, Wojtkiewicz GR et al. Selective factor XIIa inhibition attenuates silent brain ischemia: application of molecular imaging targeting coagulation pathway. *JACC Cardiovasc Imaging* 2012; 5: 1127–1138.
101. Xu Y, Cai TQ, Castriota G et al. Factor XIIa inhibition by Infestin-4: in vitro mode of action and in vivo antithrombotic benefit. *Thromb Haemost* 2014; 111: 694–704.
102. Larsson M, Rayzman V, Nolte MW et al. A factor XIIa inhibitory antibody provides thromboprotection in extracorporeal circulation without increasing bleeding risk. *Sci Transl Med* 2014; 6: 222ra17.
103. Bhandari R, Juluri KR, Resnick AC, Snyder SH. Gene deletion of inositol hexakisphosphate kinase 1 reveals inositol pyrophosphate regulation of insulin secretion, growth, and spermiogenesis. *Proc Natl Acad Sci USA* 2008; 105: 2349–2353.
104. Alvarenga PH, Xu XQ, Oliveira F et al. Novel family of insect salivary inhibitors blocks contact pathway activation by binding to polyphosphate, heparin, and dextran sulfate. *Arterioscler Thromb Vasc Biol* 2013; 33: 2759–2770.
105. Jain S, Pitoc GA, Holl EK et al. Nucleic acid scavengers inhibit thrombosis without increasing bleeding. *Proc Natl Acad Sci USA* 2012; 109: 12938–12943.
106. Smith SA, Choi SH, Collins JNR et al. Inhibition of polyphosphate as a novel strategy for preventing thrombosis and inflammation. *Blood* 2012; 120: 5103–5110.
107. Jain K, Kesharwani P, Gupta U, Jain NK. Dendrimer toxicity: Let's meet the challenge. *Int J Pharm* 2010; 394: 122–142.
108. Jones CE, Campbell RA, Brooks AE et al. Cationic PAMAM dendrimers aggressively initiate blood clot formation. *ACS nano* 2012; 6: 9900–9910.
109. Saito H, Ishihara T, Suzuki H, Watanabe T. Production and characterization of a murine monoclonal-antibody against a heavy-chain of Hageman factor (factor XII). *Blood* 1985; 65: 1263–1268.
110. Small EJ, Katzmann JA, Tracy RP et al. A monoclonal-antibody that inhibits activation of human Hageman-factor (factor XII). *Blood* 1985; 65: 202–210.
111. Pixley RA, Stumpo LG, Birkmeyer K et al. A monoclonal-antibody recognizing an icosapeptide sequence in the heavy-chain of human factor XII inhibits surface-catalyzed activation. *J Biol Chem* 1987; 262: 10140–10145.
112. Pixley RA, De La Cadena R, Page JD et al. The contact system contributes to hypotension but not disseminated intravascular coagulation in lethal bacteremia. In vivo use of a monoclonal anti-factor XII antibody to block contact activation in baboons. *J Clin Invest* 1993; 91: 61–68.
113. Jansen PM, Pixley RA, Brouwer M et al. Inhibition of factor XII in septic baboons attenuates the activation of complement and fibrinolytic systems and reduces the release of interleukin-6 and neutrophil elastase. *Blood* 1996; 87: 2337–2344.
114. Isawa H, Yuda M, Orito Y, Chinzei Y. A mosquito salivary protein inhibits activation of the plasma contact system by binding to factor XII and high molecular weight kininogen. *J Biol Chem* 2002; 277: 27651–27658.
115. Ishimaru Y, Gomez EA, Zhang FF et al. Dimiconin, a novel coagulation inhibitor from the kissing bug, *Triatoma dimidiata*, a vector of Chagas disease. *J Exp Biol* 2012; 215: 3597–3602.
116. Baeriswyl V, Calzavarini S, Gerschheimer C et al. Development of a selective peptide macrocycle

- inhibitor of coagulation factor XII toward the generation of a safe antithrombotic therapy. *J Med Chem* 2013; 56: 3742–3746.
117. Woodruff RS, Xu Y, Layzer J et al. Inhibiting the intrinsic pathway of coagulation with a factor XII-targeting RNA aptamer. *J Thromb Haemost* 2013; 11: 1364–1373.
 118. Esnouf MP, Burgess AI, Dodds AW et al. A monoclonal antibody raised against human beta-factor XIIa which also recognizes alpha-factor XIIa but not factor XII or complexes of factor XIIa with C(1)over-bar esterase inhibitor. *Thromb Haemost* 2000; 83: 874–881.
 119. Hojima Y, Pierce JV, Pisano JJ. Hageman-factor fragment inhibitor in corn seeds – purification and characterization. *Thromb Res* 1980; 20: 149–162.
 120. Ulmer JS, Lindquist RN, Dennis MS, Lazarus RA. Ecotin is a potent inhibitor of the contact system proteases factor XIIa and plasma kallikrein. *FEBS Lett* 1995; 365: 159–163.
 121. Caliezi C, Wuillemin WA, Zeerleder S et al. C1-esterase inhibitor: An anti-inflammatory agent and its potential use in the treatment of diseases other than hereditary angioedema. *Pharmacol Rev* 2000; 52: 91–112.
 122. Rajapakse N, Jung WK, Mendis E et al. A novel anticoagulant purified from fish protein hydrolysate inhibits factor XIIa and platelet aggregation. *Life Sci* 2005; 76: 2607–2619.
 123. Robert S, Bertolla C, Masereel B et al. Novel 3-carboxamide-coumarins as potent and selective FXIIa inhibitors. *J Med Chem* 2008; 51: 3077–3080.
 124. Decrem Y, Rath G, Blasioli V et al. Ir-CPI, a coagulation contact phase inhibitor from the tick *Ixodes ricinus*, inhibits thrombus formation without impairing hemostasis. *J Exp Med* 2009; 206: 2381–2395.

Anzeige

